

ACCESS SERVICE

SECTION CONTENTS

9. Directory Assistance Service..... 2

 9.1 General Description..... 2

 9.1.1 Description and Provision of
 Directory Assistance Service 3

 9.1.2 Ordering Options and Conditions 4

 9.1.3 Rate Categories 6

 9.1.4 Special Facilities Routing 8

 9.1.5 Design Layout Report 9

 9.2 Undertaking of the Telephone Company..... 9

 9.2.1 Number of Telephone Number Requests..... 9

 9.2.2 Telephone Number Availability 9

 9.2.3 Selection of DA Locations 10

 9.2.4 Transmission Specifications..... 10

 9.2.5 Testing 11

 9.2.6 Determination of Number of Transmission Paths..... 11

 9.2.7 Supervisory Signaling 11

 9.3 Obligations of the Customer..... 12

 9.3.1 Jurisdictional Reports..... 12

 9.3.2 Supervisory Signaling 12

 9.3.3 Ordering of Separate Trunk Groups..... 12

 9.3.4 Notice of Discontinuance of Service 12

 9.4 Rate Regulations..... 13

 9.4.1 Description and Application of
 Rates and Charges 13

 9.4.2 Directory Assistance Service Call Charge 14

 9.4.3 Directory Access Call Charge 14

 9.4.4 Minimum Periods 15

 9.4.5 Minimum Monthly Charge 15

 9.4.6 DA Service Rearrangements 16

 9.4.7 Moves 16

 9.4.8 Credit Allowance for Service Outages and
 Incorrect Numbers..... 16

PUBLIC UTILITY COMMISSION OF TEXAS
APPROVED

JUL - 1 '20
5 1 3 6 3
CONTROL # _____

ACCESS SERVICE

9. Directory Assistance Service

The Telephone Company will provide Directory Assistance (DA) Service to a customer from Directory Assistance Service locations (DA locations). DA locations are either primary or subtending. Primary DA locations are those to which terminating DA calls for the NPA first complete. Primary DA locations either process the telephone number request or, if necessary, forward the call to a subtending DA location for processing. DA service rates are assessed by the primary DA location only. Subtending DA locations are compensated by contractual arrangements between telephone companies.

9.1 General Description

Telephone Company provided DA Service is available to customers for their use in furnishing DA services to end users. It provides for the use of Directory Access Service between the premises of the ordering customer and the DA location(s), use of DA access equipment, and use of DA operators to provide telephone numbers.

Directory Access Service will be provided between the customer designated premises and the DA location by the Telephone Company. Rates and charges for Directory Assistance Service are set forth in Section 17.6.2 following. When Switched Access Service is used at the terminating end of the DA call in combination with Directory Access Service in the provision of Directory Assistance Service, Switched Access Services rates do not apply on the terminating end of the call, whereas the Directory Assistance Service rates do apply.

PUBLIC UTILITY COMMISSION OF TEXAS
APPROVED

JUL - 1 '20
RECORDED
5 13 63

CONTROL # _____

ACCESS SERVICE

9. Directory Assistance Service (Cont'd)

9.1 General Description (Cont'd)

9.1.1 Description and Provision of Directory Assistance Service

A Telephone Company DA operator, when furnished a name and locality, will provide or attempt to provide the telephone number listed in the Telephone Company DA records associated with the name given, at the rates and charges as set forth in Section 17.6.2 following. The Telephone Company's contact with the customer's end user shall be limited to that effort necessary to process a customer's end user's request for a telephone number; and the Telephone Company will not transfer, forward or redial a customer's end user call to any other location for any purpose other than the provision of DA Service.

Each Directory Access Service will consist of the following:

- An Interface Group equipped with an available Premises Interface at the customer's designated premises as set forth in Section 15.3.1 following.
- Directory Transport between the premises of the ordering customer and the DA location.

When required by the Telephone Company, a separate Directory Access Service trunk group will be provided for DA Service for each NPA. Separate trunk groups will be required when the Telephone Company notifies the customer that the mechanized search of its data base and its mechanized operator practices require a mechanized identification of the NPA code for which the customer's end user desires DA information.

Further, when an access tandem is available and is provided, the Directory Access Service will be provided, at Telephone Company choice:

- as a separate Directory Access Service trunk group, or
- in combination with FGB, FGC or FGD Switched Access Service.

**PUBLIC UTILITY COMMISSION OF TEXAS
APPROVED**

JUL - 1 20 DOCKET 5 13 03

CONTROL # _____

ACCESS SERVICE

9. Directory Assistance Service (Cont'd)

9.1 General Description (Cont'd)

9.1.2 Ordering Options and Conditions

(A) Ordering

Except as set forth following, Directory Assistance Service provided under a Special Order is subject to the ordering conditions as set forth in Section 5 preceding. The customer shall determine and order the busy hour minutes of capacity and interface type of Directory Access Services it needs for DA Service.

When DA Service is initially ordered, the customer shall order the service for at least six months. Thereafter, additional service may be ordered for a minimum of six months. Not later than three months prior to the end of the six month period, the customer shall notify the Telephone Company if the service is to be discontinued at the end of the six month period. If no notice is received from the customer, the Telephone Company will automatically extend the service for another six months and all appropriate charges as set forth in Section 17.6.2 following will apply for another six months.

**PUBLIC UTILITY COMMISSION OF TEXAS
APPROVED**

JUL - 1 '20 5 1 3 6 3

DOCKET

CONTROL # _____

ACCESS SERVICE

9. Directory Assistance Service (Cont'd)

9.1 General Description (Cont'd)

9.1.2 Ordering Options and Conditions (Cont'd)

(B) Cancellation of a Special Order

A customer may cancel a Special Order for DA Service on any date prior to the service date. The cancellation date is the date the Telephone Company receives written or verbal notice from the customer that the Special Order is to be canceled. The verbal notice must be followed by written confirmation within 10 days.

When a customer cancels a Special Order for DA Service after the order date but prior to the start of service, the appropriate application of charges as set forth in Section 5 preceding apply for the Directory Access Service canceled. In addition, a charge equal to any unrecoverable capital costs incurred by the Telephone Company will apply to the customer.

(C) Changes to Special Orders

When a customer requests changes to a pending order for DA Service, such changes will be undertaken if they can be accommodated by the Telephone Company. The appropriate application of charges as set forth in Section 5 preceding apply for the Directory Access Service changed. In addition, a charge equal to any other costs incurred by the Telephone Company because of the change will apply.

PUBLIC UTILITY COMMISSION OF TEXAS
APPROVED

JUL - 1 '20 5 13 6 3

TEKCO
T

CONTROL # _____

ACCESS SERVICE

9. Directory Assistance Service (Cont'd)

9.1 General Description (Cont'd)

9.1.3 Rate Categories

There are two rate categories which apply to Directory Assistance Service:

- Directory Assistance Service Call
- Directory Transport Service

The following diagrams depict generic views of the components of Directory Assistance Service when provided on a directly trunked basis and when provided in combination with trunk side Switched Access Service FGB, FGC or FGD on the terminating end of a call.

Directly Trunked

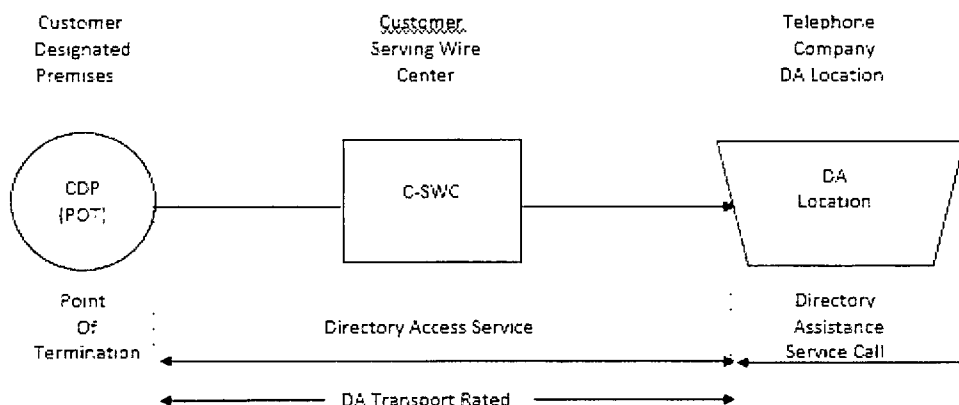

In Combination with Switched Access Service

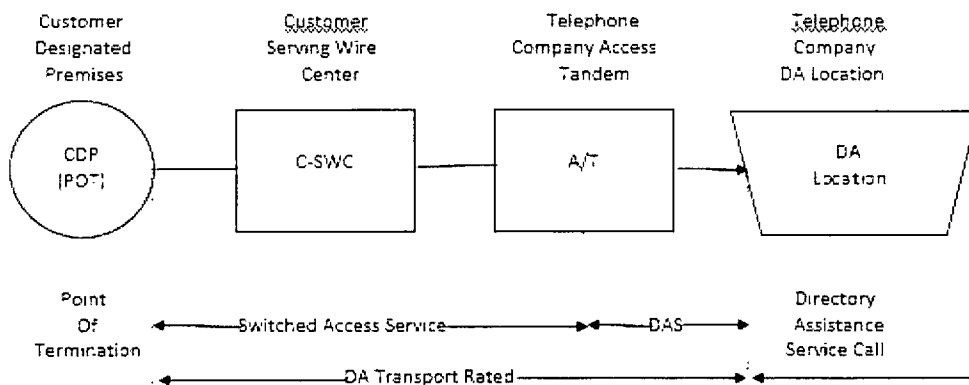

PUBLIC UTILITY COMMISSION OF TEXAS
APPROVED

LOCKET

Issued: June 4, 2021

JUL - 1 '20

5 13 03

Effective: July 1, 2020

CONTROL # _____

ACCESS SERVICE

9. Directory Assistance Service (Cont'd)

9.1 General Description (Cont'd)

9.1.3 Rate Categories (Cont'd)

(A) Directory Assistance Service Call

The Directory Assistance Service Call rate category provides for the use of general DA Services such as operators and DA access equipment necessary to provide DA Service to a customer.

(B) Directory Access Service

Directory Access Service is provided in the form of Directory Transport which provides the transmission facilities and transport termination between the premises of the ordering customer and the DA location.

Directory Transport is a two-way voice frequency transmission path composed of facilities determined by the Telephone Company. The two-way voice frequency path transports calls in the terminating direction (from the premises of the ordering customer to the DA location).

The Telephone Company will determine whether the Directory Access Service is to be routed directly to a DA location or through an access tandem switch appropriately equipped for DA measurement and served by DA trunks to the DA location when such an access tandem switch is available. The combination of FGB, FGC or FGD Switched Access Service with DA Service will only be provided at such available and appropriately equipped access tandem switches. If the customer desires the traffic routing to be other than that selected by the Telephone Company, it may request a cooperative effort to determine if customer specified traffic routing can be used in lieu of the Telephone Company selected traffic routing.

PUBLIC UTILITY COMMISSION OF TEXAS
APPROVED
JUL - 1 20 5 13 03
DOCKET
CONTROL # _____

ACCESS SERVICE

9. Directory Assistance Service (Cont'd)9.1 General Description (Cont'd)9.1.3 Rate Categories (Cont'd)(B) Directory Access Service (Cont'd)

When Directory Transport is provided using a direct route to the DA location, no address signaling is provided. When Directory Transport is provided with the use of an access tandem switch, wink start-start pulsing signaling is provided at the access tandem switch. The customer will be notified by the Telephone Company when access tandem routing is provided and the customer shall address each call to the DA location using NPA + 555 + 1212 or when required by the Telephone Company, 555-1212. Only NPA codes handled by the DA location served by the access tandem switch will be processed.

Directory Transport is provided with one of the Local Transport Interface Groups as set forth in Section 15.1.1 following.

9.1.4 Special Facilities Routing

A customer may request that Directory Access Service be provided via Special Facilities Routing. The regulations, rates and charges for Special Facility Routing (Avoidance, Diversity and Cable Only) are as set forth in Section 11 following.

PUBLIC UTILITY COMMISSION OF TEXAS
APPROVED
JUL - 1 '20 5 13 6 3
CONTROL # _____

ACCESS SERVICE

9. Directory Assistance Service (Cont'd)

9.1 General Description (Cont'd)

9.1.5 Design Layout Report

The Telephone Company will provide to the customer the makeup of the facilities and services provided under this section as Directory Access Service. This information will be provided in the form of a Design Layout Report similar to that as set forth in Section 6.1.5 preceding. Design Layout Reports for Directory Access Service will be provided only when specifically requested by the customer. The Design Layout Report will be provided to the customer at no charge, and will be reissued or updated whenever the facilities provided for the customer's use are materially changed.

9.2 Undertaking of the Telephone Company

9.2.1 Number of Telephone Number Requests

A maximum of two (2) requests for telephone numbers will be accepted per call to Directory Assistance and DA operators will not transfer, forward or redial the call to another location for any purpose other than the provision of DA Service.

9.2.2 Telephone Number Availability

A telephone number which is not listed in DA records will not be available to the customer's end user.

PUBLIC UTILITY COMMISSION OF TEXAS
APPROVED
JUL - 1 '20 5 13 6 3
CONTROL # _____

ACCESS SERVICE

9. Directory Assistance Service (Cont'd)

9.2 Undertaking of the Telephone Company (Cont'd)

9.2.3 Selection of DA Locations

The Telephone Company will specify the DA location which provides the DA Service for each numbering plan area code (NPA). The DA locations are as shown in NATIONAL EXCHANGE CARRIER ASSOCIATION, INC. TARIFF F.C.C. NO. 4.

When it becomes necessary to change a DA location, as determined by the Telephone Company, the Telephone Company will notify the involved customers six months prior to the change. For such changes, the regulations as set forth in Section 2.1.7 preceding apply.

9.2.4 Transmission Specifications

Each Directory Assistance Service transmission path is provided with standard transmission specifications, either Type A or B, as set forth respectively in Section 15.1.2(E) and (F) following. The specifications associated with the parameters are guaranteed to the DA location. The standard for a particular transmission path is dependent upon the following:

- whether Directory Access Service is provided in combination with FGB, FGC or FGD Switched Access Service, or
- when not provided in combination with Switched Access Service, whether routed direct or via an access tandem switch.

The available transmission specifications are set forth in Section 15.3.2 following.

PUBLIC UTILITY COMMISSION OF TEXAS
APPROVED
 JUL - 1 '20 5 13 6 3
 LOCKET
 CONTROL # _____

ACCESS SERVICE

9. Directory Assistance Service (Cont'd)

9.2 Undertaking of the Telephone Company (Cont'd)

9.2.5 Testing

(A) Acceptance Testing

The acceptance testing capabilities for Directory Access Service traffic routed through an access tandem are the same as those for the associated FGC or FGD end office switching. The acceptance testing for Directory Access Service traffic routed directly, or routed in separate trunk groups through an access tandem, to the DA location, will be the same as that for Switched Access Service as set forth in Section 6.2.4 preceding.

(B) Routine Testing

Routine testing capabilities for Directory Access Service traffic routed through an access tandem are the same as those for the associated FGC or FGD end office switching. Routine testing capabilities for Directory Access Service traffic routed directly, or routed in a separate trunk group through an access tandem, to the DA location, will be as set forth in Section 13.3.1 following.

9.2.6 Determination of Number of Transmission Paths

The number of Directory Transport transmission paths provided is based on the customer's order and is determined by the Telephone Company in a manner similar to Switched Access Service transmission paths as set forth in Section 6.2.5 preceding.

9.2.7 Supervisory Signaling

Trunk side switching is provided at the DA Service access location. The DA Service access location will provide trunk answer and disconnect supervisory signaling.

PUBLIC UTILITY COMMISSION OF TEXAS
APPROVED

JUL - 1 '20 **DOCKET** 5 13 6 3

CONTROL # _____

ACCESS SERVICE

9. Directory Assistance Service (Cont'd)

9.3 Obligations of the Customer

In addition to the obligations of the customer as set forth in Section 2 preceding, the customer has certain specific obligations concerning the use of Directory Assistance Service. These obligation are as follows:

9.3.1 Jurisdictional Reports

Directory Transport may, at the option of the customer, be provided for both interstate and intrastate communications. When the customer requests such mixed access, the intrastate Directory Transport charges will be determined by the Telephone Company using the data furnished by the customer as set forth in Section 2.3.11 preceding.

9.3.2 Supervisory Signaling

The customer facilities at the premises of the ordering customer shall provide the necessary on-hook and off-hook supervision.

9.3.3 Ordering of Separate Trunk Groups

When requested by the Telephone Company, the customer shall order a separate trunk group for DA Service for each NPA. The conditions when the customer will be requested to order separate trunk groups for each NPA are set forth in Section 9.1.1 preceding.

9.3.4 Notice of Discontinuance of Service

DA Service is ordered and renewed for a minimum period of six months at a time, as set forth in Section 9.1.2(A) preceding. Not later than three months prior to the end of any six month period, the customer shall notify the Telephone Company if the service is to be discontinued at the end of that period.

**PUBLIC UTILITY COMMISSION OF TEXAS
APPROVED**

JUL - 1 '20

5 13 6 3

DOCKET

CONTROL # _____

ACCESS SERVICE

9. Directory Assistance Service (Cont'd)

9.4 Rate Regulations

This section contains the specific regulations governing rates and charges that apply for Directory Assistance Service.

9.4.1 Description and Application of Rates and Charges

There are two types of rates and charges that apply to Directory Assistance Service. These are usage rates and nonrecurring charges.

(A) Usage Rates

Usage rates for DA Service are rates that are applied on a per call basis. Per call charges are accumulated over a monthly period.

(B) Nonrecurring Charges

Nonrecurring charges for DA Service are one-time charges that apply for a specific work activity (i.e., installation, change to an existing service and DA Service rearrangements).

(1) Installation of Service

Nonrecurring charges apply to each Directory Access Service installed. Directory Access Service is ordered on a busy hour minutes of capacity basis and the number of Directory Transport transmission paths installed is based on the customer's order, and is determined by the Telephone Company in a manner similar to Switched Access Service transmission paths as set forth in Section 6.2.5 preceding.

(2) DA Service Rearrangements

All changes to existing services other than changes involving administrative activities will be treated as a discontinuance of the existing service and an installation of a new service.

**PUBLIC UTILITY COMMISSION OF TEXAS
APPROVED**

JUL - 1 '20 **BOOKED** 5 13 6 3

CONTROL # _____

ACCESS SERVICE

9. Directory Assistance Service (Cont'd)

9.4 Rate Regulations (Cont'd)

9.4.2 Directory Assistance Service Call Charge

The Directory Assistance Service call charge, as set forth in Section 17.6.2(A) following, applies for each call to DA Service. A call is a call which has been answered by a DA operator. The charge applies whether or not the DA operator provides the requested telephone number. The number of calls answered by DA operators will be accumulated by Telephone Company measuring equipment. A credit for the provision of an incorrect telephone number will be applied as set forth in Section 9.4.8 following.

9.4.3 Directory Access Call Charge

The Directory Transport provides the transmission facility and transport termination from the serving wire center for the premises of the ordering customer to the DA location. Title Page notwithstanding, these two wire centers may be in different LATAs. In addition, the premises of the ordering customer must be in the LATA where DA service is requested or in the LATA where the DA location is located. The rate for Directory Transport is calculated on a per call basis for the appropriate mileage band. The mileage band for Directory Transport is measured from the serving wire center for the premises of the ordering customer to the DA location. The measurement will be performed as set forth in Section 6.4.6 preceding.

The charge per call for Directory Transport, as set forth in Section 17.6.2 following applies, for each call to DA service. A call is as set forth in Section 9.4.2 preceding. The number of calls will be accumulated as set forth in Section 9.4.2 preceding.

**PUBLIC UTILITY COMMISSION OF TEXAS
APPROVED**

JUL - 1 '20
5 13 6 3
CONTROL # _____

ACCESS SERVICE

9. Directory Assistance Service (Cont'd)

9.4 Rate Regulations (Cont'd)

9.4.4 Minimum Periods

The minimum period for which DA Service and the Directory Access Service is provided and for which charges apply is six months. A minimum period of six months applies for each additional period of service ordered or extended.

If DA Service is discontinued prior to the end of each six month period, the charges that apply for the remaining months are the non-recoverable costs. Such costs include the non-recoverable cost of equipment and material ordered, provided or used, plus the non-recoverable cost of installation and removal including the costs of engineering, labor supervision, transportation, rights-of-way and other associated costs less estimated net salvage.

9.4.5 Minimum Monthly Charge

DA Service is subject to a minimum monthly charge. The minimum monthly charge is calculated as follows:

- The minimum monthly charge for Directory Assistance Service calls is the charge as set forth in Section 17.6.2 following for the actual usage for the month.
- For the Directory Transport rate element, the minimum monthly charge the customer will be assessed will be the usage charges based on actual usage. Rates for actual usage are set forth in Section 17.6.2 following.

**PUBLIC UTILITY COMMISSION OF TEXAS
APPROVED**

JUL - 1 '20 DOCKET 5 13 6 3

CONTROL # _____

ACCESS SERVICE

9. Directory Assistance Service (Cont'd)

9.4 Rate Regulations (Cont'd)

9.4.6 DA Service Rearrangements

Nonrecurring charges apply for service rearrangements. Service rearrangements and the regulations concerning the application of associated nonrecurring charges are as set forth in Section 6.4.1(B)(3) preceding.

9.4.7 Moves

A move involves a change in the physical location of the point of termination at the customer designated premises or of the customer designated premises. Moves will be treated as set forth in Section 6.4.4 preceding and all associated nonrecurring charges will apply. Minimum period requirements will be established at the new location as set forth in Section 6.4.4 preceding. The customer will also remain responsible for satisfying all outstanding minimum period charges for the discontinued service.

9.4.8 Credit Allowance for Service Outages and Incorrect Numbers

(A) When the DA location or DA operator equipment or terminals are out of service due to a Telephone Company equipment failure a credit allowance is provided. When an incorrect number is provided and a customer DA call has been answered by a DA operator, a credit allowance is provided. The credit allowances provided are equal to the rate for a Directory Assistance Service Call plus the rate for a Directory Transport call as set forth respectively in Section 17.6.2(A) and (B) following. The rate for a Directory Transport call will be the average of the Directory Transport rates per call as set forth in Section 17.6.2(B) following. The credit will be applied to the customer's charges.

PUBLIC UTILITY COMMISSION OF TEXAS
APPROVED

JUL - 1 '20

5 1 3 6 3

BOOKET

CONTROL # _____

ACCESS SERVICE

9. Directory Assistance Service (Cont'd)

9.4 Rate Regulations (Cont'd)

9.4.8 Credit Allowance for DA Service (Cont'd)

- (B) In addition to the credit as set forth in (A) preceding, when a DA operator or DA equipment provides an incorrect number for a call and the customer reports such occurrences to the Telephone Company, a credit allowance for the Switched Access portion of the call in the originating LATA of such DA call will apply. The credit will be as set forth in (C) following. When the customer reports such a call and the number requested, the number provided and the reason the number provided is incorrect, the number of calls for which a credit will apply will be developed by the Telephone Company in cooperation with the customer.

- (C) When a DA call is not completed due to the failure of Directory Access Service to DA locations, DA access equipment or DA operator activities, a credit allowance for the Switched Access Service portion in the originating LATA of such DA call will apply. When the customer reports such a call and DA number dialed, time of the call and the date of the call, the number of calls for which a credit will apply will be developed by the Telephone Company in cooperation with the customer. The credit will be as set forth in Section 17.6.2(C) following. Credit allowances for other service interruptions will be provided as set forth in Section 2.4.4 preceding.

PUBLIC UTILITY COMMISSION OF TEXAS
APPROVED
JUL - 1 '20 DOCKET 5 13 03
CONTROL # _____